

## LOW LOCATION LIGHTING

### Low Location Lighting System



The spreading of smoke is one of the most dangerous consequences of a fire rendering evacuation difficult and in some cases impossible. Under these conditions, visibility is reduced causing panic and increasing the evacuation time which is a critical factor in avoiding intoxication which can lead to death.

The © Everlux® Low Location Lighting (LLL) system is a unique system that allows all evacuation routes to stay illuminated, thereby communicating a clear, continuous and unambiguous “means of escape” message which leads to a safe place. The locations of fire fighting equipment are also clearly marked as part of the system along the escape routes.

This LLL system is unique in providing consistent and regular information throughout the complete escape route. This reduces possible confusion and panic, factors that hamper the safe egress from occupied areas.

According to IMO Resolution A. 752 [18] all means of egress must be marked with Low Location Lighting system at all points of the evacuation route. The LLL system is also recommended by ISO Standards, namely ISO 15370.



The illustration below depicts a complete safety signage system installed on board:

- A** - Photoluminescent signs installed at a high location level (above 2m) are to be visible and identified from further distances.
- B** - Photoluminescent signs installed at an intermediate location level. Per ISO 24409 fire-fighting equipment signs shall be installed either directly on the fire-fighting equipment or as close as practicable. Recommended range for signs with text providing information and/or instructions to the user.
- C** - Photoluminescent signs at a low location level (within 30cm from deck according to SOLAS 2004 Chapter II Regulation 13.3.3.5 and ISO 15370): a sign system that illuminates the entire escape route and identifies the location of fire fighting equipment at floor level.

Examples

Escape doors should be signed as illustrated.

Stairwells and corridors which are 2m wide or wider should be fitted with LLL photoluminescent strips on both sides.

Photoluminescent directional signs must be placed at each change of level.

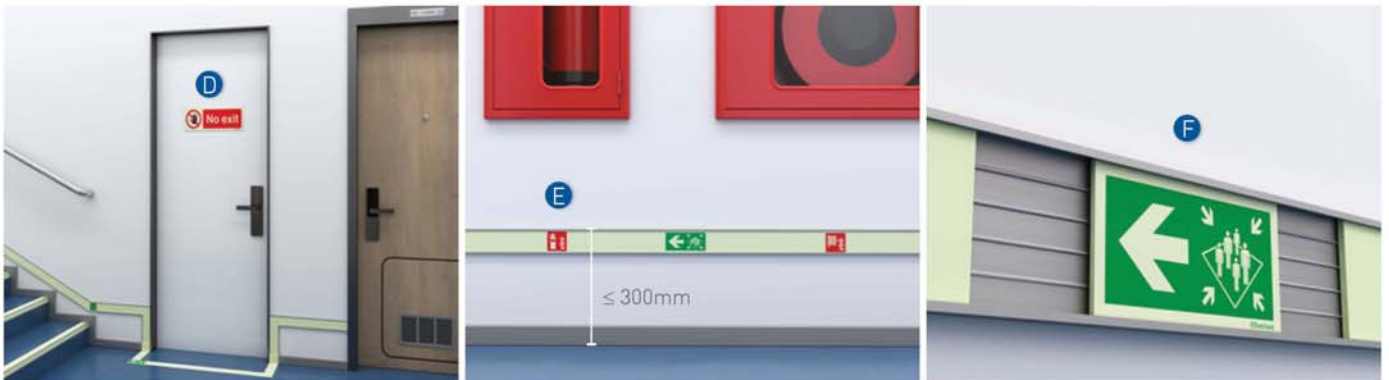

No exit signs must be posted on doors that are not part of the escape route.

According to Solas 2004 Chapter II Regulation 13.3.3.5 and IMO Resolution A.752 [18] photoluminescent marking strips must be placed not more than 30cm above the deck at all points of the escape route.

Directional escape route signs complement the continuous photoluminescent strip installed in aluminium rail.

## LOW LOCATION LIGHTING

### Normative and Legal Framework, Technical Performances and Properties

Guidance systems at floor level (Low Location Lighting) began with legislation covering the areas of greatest risk. Firstly in aviation with FAA in 1984 and then in the maritime industry with IMO Regulations in 1989. Since 1999, following the development of new photoluminescent technologies, other authorities have begun the process of standardising these systems.

IMPORTANT STANDARDS	IMO Resolution A.752 [18]	Guidelines for the evaluation, testing and application of low-location lighting on passenger ships
	SOLAS Convention 2004	Means of escape - Marking of escape routes
	European Directive 2014/90/EU	Safety rules and standards for passenger ships
	ISO 15370	Low Location Lighting (LLL) on passenger ships
	ISO 16069	SWGS - Safety Way Guidance Systems
	ISO 3864	Graphical symbols - safety colours and safety signs

#### ⊗ Everlux® Low Location Lighting Strip and Sign System:

The strip and sign system can be mounted directly to walls using the ⊗ Everlux® adhesive or with the aluminium frames.

According to IMO A.752 [18] this system shall be positioned in the following way, throughout the escape routes:

- Where a corridor has a width of 2m or more the guidance line shall be applied continuously on both sides of the corridor.
- Where the width is less than 2m, one guidance line may be sufficient and should be as continuous as possible on the side where the fire fighting equipment is located. If there is no fire fighting equipment the strips should be applied continuously on the side that leads to the door handle.
- The strips should not be installed more than 300mm above deck.

Strip and Sign System for Floors and Stairs:

The strip and sign system can be placed directly onto floors and stairs using the integral high adherence adhesive. Simply remove the backing material and position accurately.

Luminance Properties			
Applicable Resolutions and Standards/ Product	Luminance Intensity (mcd/m <sup>2</sup> ) (After removing the exciting light)		Period of Light Decay Luminance Intensity greater than a 0.3 mcd/ m <sup>2</sup>
	10 minutes	60 minutes	
IMO Resolution A.752[18] a)	15 mcd/m <sup>2</sup>	2.0 mcd/m <sup>2</sup>	...
ISO 15370 a)	15 mcd/m <sup>2</sup>	2.0 mcd/m <sup>2</sup>	...
⊗ Everlux® a)	<b>57 mcd/m<sup>2</sup></b>	<b>10.7 mcd/m<sup>2</sup></b>	<b>3000 minutes</b>
⊗ Everlux®-LLL b)	<b>80 mcd/m<sup>2</sup></b>	<b>10 mcd/m<sup>2</sup></b>	<b>1000 minutes</b>

a) Values obtained with a stimulation of only 25 lux, during 24 hours with a fluorescent lamp with colour temperature of 4000K, according to ISO 15370 measurement protocol.

b) Values obtained with a stimulation of only 25 lux, during 15 minutes with a fluorescent lamp with colour temperature of 6500K, according to ISO 16069 measurement protocol.

All signs have a high photoluminescent intensity which is achieved with as little as a 25 lux charge from an ambient light source

#### Base Materials:

**Signs and strips for wall mounting:** Photoluminescent rigid plastic 1.2mm thick; photoluminescent self-adhesive vinyl;

**Signs and strips for floors and stairs:** Photoluminescent non-slip self-adhesive polycarbonate 0.62mm thick;

Transparent vinyl signs are also available to complement the ⊗ Everlux® Low Location Lighting system.

**Printing:** Serigraphy, high gloss paint with a high UV resistance.

**Chemical Characteristics:** Non-phosphorous, non-radioactive, lead-free and non-poisonous.

## Turnkey Safety Signage Projects



Ⓢ Everlux® adopts an integrative approach to every safety signage project the company is involved with, from project development through installation and commissioning. When hiring Ⓢ Everlux® for a turnkey safety signage project, customers benefit from a high quality on time service which includes on-board and remote surveys, life-safety and fire control plan and Low Location Lighting project development using the Ⓢ Everlux® Project maritime tool, supply, installation, on-board luminance measurements, project management, documentation and delivery.

The Ⓢ Everlux® turnkey safety signage project service is the ideal solution for owners, shipyards or marine outfitters who are involved with new-build or major refurbishment on vessels or oil rigs.

## Photoluminescent Low Location Lighting System Inspections and Measurement Service

Ⓢ Everlux® has the Approval as Service Supplier by DNV for Low Location Lighting luminance measurements.

Our technicians are available worldwide to help you meet the classification bodies' requirements in a fast and cost-effective way.

The inspection and measurement reports on LLL systems are mandatory according to IMO Resolution A.752 [18], adopted on 4 November 1993. These guidelines cover the approval, installation and maintenance of low location lighting (LLL) required by regulations II-2/28, paragraph 1.10 and II-2/41-2, paragraph 4.7 of the 1974 SOLAS Convention, as amended, on all passenger ships carrying more than 36 passengers, to readily identify the passengers' route of escape when the normal emergency lighting is less effective due to smoke.

According to IMO Resolution A.752 [18], chapter 9, a maintenance of LLL systems should be visually examined and checked once a week and a record kept. All missing, damaged or inoperable LLL components should be replaced.

All LLL systems should have their luminance tested at least once every five years.

Readings should be taken on site. If the luminance for a particular reading does not meet the requirements, additional readings shall be taken. The readings shall be taken adjacent to the location of the non-compliant readings. The installation is acceptable when the spacing of the non-compliant readings does not exceed 2 m. Otherwise, the LLL component shall be replaced or the illumination increased to meet the requirements.



For detailed information on the Ⓢ Everlux® turnkey safety signage project service or on the mandatory requirements, inspection and measurement reports of photoluminescent LLL systems, please contact us at [commercial@everluxmaritime.com](mailto:commercial@everluxmaritime.com).



© Everlux® project maritime is a software support tool for the development of safety signage and Low Location Lighting (LLL) projects and respective bill of quantities. This tool facilitates the most adequate selection of safety signs and provides installation companies with the right technical documentation to assure that the safety signs that are projected will be installed onboard simultaneously reducing the installation time.

© Everlux® project maritime is available in two different versions: version 3.0 and version 3.0i. In terms of hardware both versions can be used with 64 bit processors. The 3.0 version works on AutoCAD (post 2012 versions except AutoCAD LT) and after its installation will automatically generate a tool bar with the © Everlux® project maritime menu.

The 3.0i version is an independent application that allows the use of image files (type \*.dxf; \*.jpg; \*.bmp; \*.png) as the basis for the safety signage project.

© Everlux® project maritime is available for free download at: [www.everluxmaritime.com/en/downloads](http://www.everluxmaritime.com/en/downloads)

## AutoCAD Symbols for Fire & Safety Control Plans

**Everlux®**

**AUTOCAD SYMBOLS  
FOR FIRE & SAFETY  
CONTROL PLANS**

IMO Resolution A.1116 [30] - Escape Route Signs and Equipment Location Markings is now in force. This recent resolution introduced graphical changes to shipboard safety signs to allow for an easier understanding of the signs by crews and passengers. These new signs have been available in the Everlux catalogue and the Everlux website ever since ISO 24409 was published.

In addition to its safety signs, Everlux is now providing a file with AutoCAD blocks with the graphical symbols compliant with IMO Resolution A.1116 [30]. This is particularly useful for shipyards and naval architects involved in the development of Fire & Safety Control Plans.

The AutoCAD file with the IMO Resolution A.1116 [30] is available free of charge. If you are interested in receiving it, please e-mail us at [commercial@everluxmaritime.com](mailto:commercial@everluxmaritime.com) or contact us via our website [www.everluxmaritime.com](http://www.everluxmaritime.com).

Signs for Wall Marking at Floor Level

The signs featured in this page can be supplied in photoluminescent rigid plastic, self-adhesive photoluminescent vinyl and transparent self-adhesive vinyl. The transparent self-adhesive vinyl signs are a quick solution to complement Low Location Lighting systems by applying them directly on to the photoluminescent strips.

[mm]  
107x57  
158x83



S 20 01

S 20 02

S 20 03

S 20 04

S 20 05

S 20 06

S 20 07

S 20 08

S 20 09

S 20 10



S 20 21

S 20 22

S 20 23

S 20 24

S 20 25

S 20 26

S 20 27

S 20 28

S 20 29

S 20 81

S 20 82

S 20 83

S 20 84

[mm]  
57x57  
83x83



(\*) S 20 31

(\*) S 20 32

S 20 47

S 20 49

S 20 40

S 20 51

S 20 50

S 20 54

S 20 55

(\*) S 20 33

(\*) S 20 34

S 20 42

S 20 43

S 20 46

S 20 44

S 20 41

S 20 52

[mm]  
57x57  
83x83  
(\*)75x57  
(\*)110x83



S 20 61

[mm]  
107x57  
158x83



S 20 65



S 20 66



S 20 67

[mm]  
107x57  
158x83

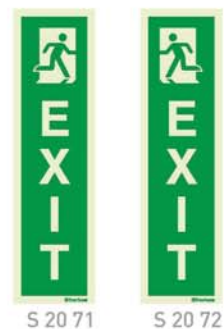

S 20 71

S 20 72

[mm]  
57x200  
83x300

Available in photoluminescent rigid plastic and non-slip self-adhesive polycarbonate.



S 20 75

[mm]  
200x40

## LOW LOCATION LIGHTING

### Strips for Wall Marking at Floor Level

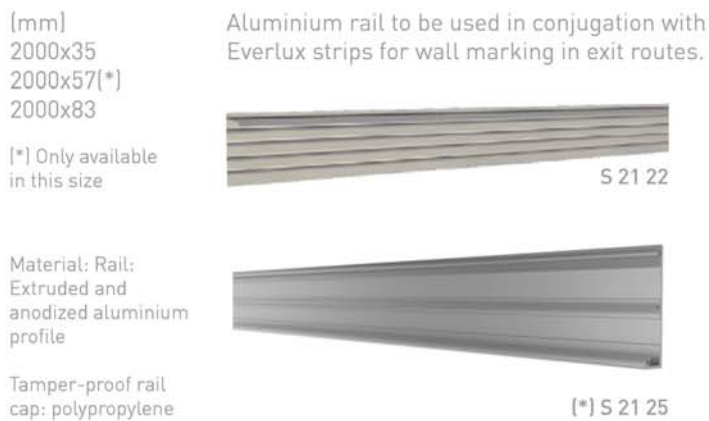
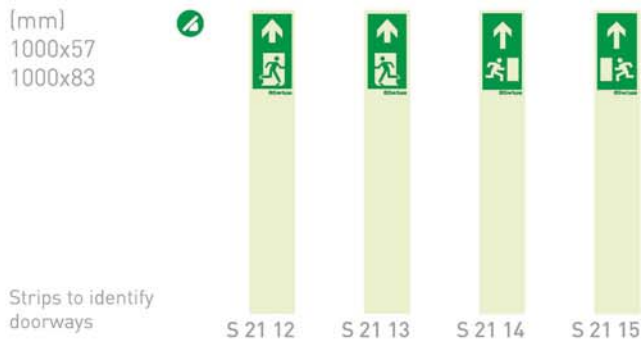

### Rolls for Wall Marking

length [m]  
10

The **Everlux**® photoluminescent vinyl rolls can be used in wall mounted LLL systems and are the ideal solution for applications in irregular or rounded walls. This product can also be used for emergency equipment marking and handrail identification.

width [mm]  
35  
57  
83



System for Floor and Stair Marking

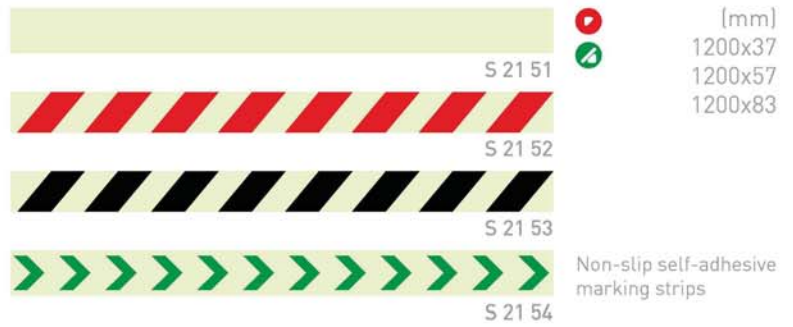

⊗ Everlux®-LLL Discs

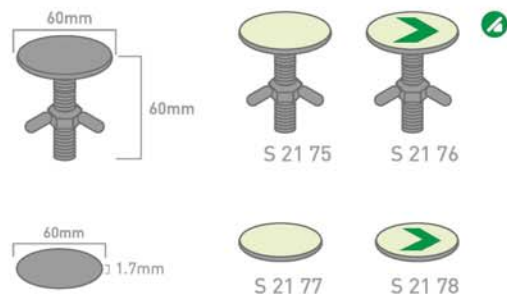

Discs for mesh metal floors  
Ø60 – 1 box of 12 units

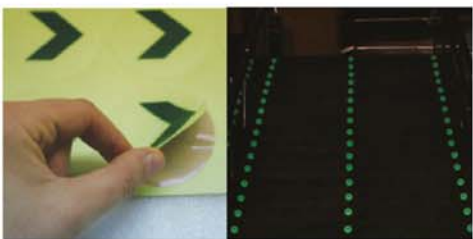

Non-slip self-adhesive discs for floors  
Ø40 – 1 sheet of 16 units  
Ø60 – 1 sheet of 18 units  
Ø100 – supplied by the unit

⊗ Everlux®-LLL Footprint Silhouettes

Photoluminescent footprint silhouettes are ideal for indicating the direction and outline of evacuation routes. Available in left and right silhouettes to be used alternately, ⊗ Everlux®-LLL Footprint Silhouettes are made from self-adhesive, anti-slip polycarbonate which is only 0.03mm thick.

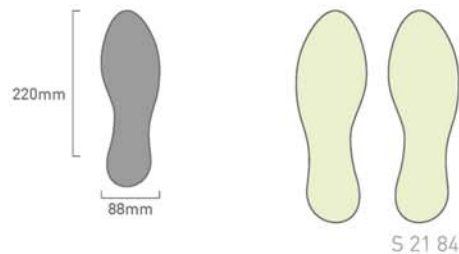
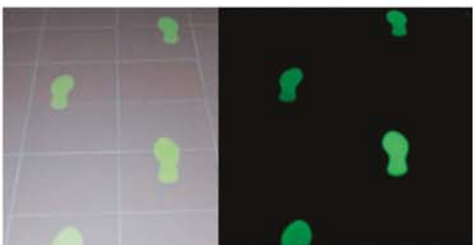



## LOW LOCATION LIGHTING

### Non-Slip Self-Adhesive "L" for Stairs

Designed to mark the edges of the steps. Supplied in sheets of 4 units (two signs per step)

In every flight of steps, the limits of the first and the final steps should be fully signed. You should use the strips code S 21 51

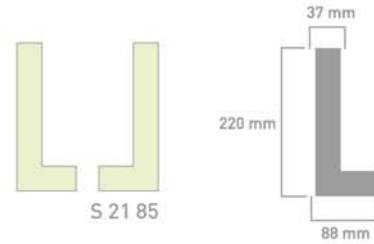

### Stairnosing - Protection for Steps



Protection for steps

S 21 90

Aluminium framework developed for stair nosing protection. This product has anti-slip properties, even in situations where oil has been spilt, due to the grooves featured over the whole surface.

On the upper and front parts there are **Everlux<sup>®</sup> LLL** photoluminescent polycarbonate strips which also have anti-slip properties. These allow the perfect identification of the edge of the steps during a descending or ascending evacuation.

#### Properties

Materials: Aluminium and **Everlux<sup>®</sup> LLL** in 0.62mm thick polycarbonate.

Sizes: Please refer to the technical drawings.

The **Everlux<sup>®</sup>** protection for steps is supplied with double-sided high adherence adhesive which allows an easy application.

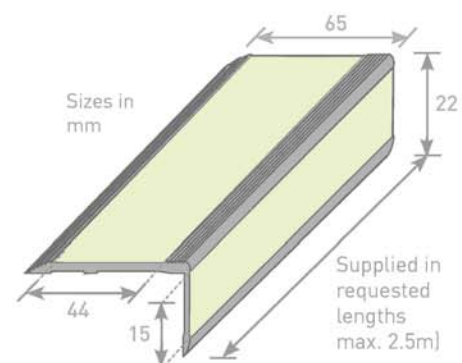

Join the frame at two points, as in scheme 1, then rotate towards the riser until it is firmly adhered (scheme 2).

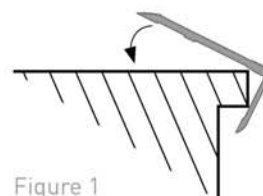

Figure 1

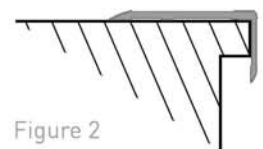

Figure 2

Signs to Prohibit Dangerous Actions



					<p> [mm]                  100x100                  150x150                  200x200                  (*)300x300</p>
(*) S 38 01	S 38 11	(*) S 38 02	S 38 12	(*) S 38 03	
					
S 38 04	S 38 05	S 38 06	S 38 07	S 38 08	S 38 09
					
S 38 10	S 39 01	S 39 02	S 39 03	S 39 04	S 39 05
					
S 39 06	S 39 07	S 39 08	S 39 09	S 39 10	S 39 11
					
S 39 12	(*) S 39 13	S 39 14	S 39 15	S 39 16	S 39 17
					
S 39 18	S 39 19	S 39 20	S 39 21	S 39 22	S 39 23

# PROHIBITION SIGNS (PSS)

## Signs to Prohibit Dangerous Actions

(mm)  
300x100  
400x150  
600x200(\*)

(\*) Also available  
in this size

	<b>No smoking</b> S 38 51		<b>All smoking strictly prohibited</b> S 38 52		<b>This is a no smoking area</b> S 38 53
	<b>No smoking beyond this point</b> S 38 54		<b>No electronic cigarettes</b> S 38 77		<b>No naked lights</b> S 38 55
	<b>No naked flames</b> S 38 56		<b>No hot work</b> S 38 57		<b>No matches</b> S 38 73
	<b>Open flame and smoking prohibited</b> S 38 74		<b>No naked lights beyond this point</b> S 38 75		<b>No matches or cigarette lighters</b> S 38 79
	<b>No exit</b> (*) S 38 58		<b>No entry</b> (*) S 38 59		<b>Hot works prohibited</b> S 38 80
	<b>No hot work during gas freeing or cargo operations</b> S 38 81		<b>Do not ride on forks</b> S 38 82		<b>No eating or drinking</b> S 38 83
	<b>No eating or drinking within this area</b> S 38 84		<b>No pushing</b> S 38 85		<b>No sitting</b> S 38 86
	<b>Unsteady object Do not push</b> S 38 87		<b>No stepping on surface</b> S 38 88		<b>Do not step on this surface</b> S 38 89
	<b>Do not walk or stand here</b> S 38 90		<b>Do not tie knots in rope</b> S 38 91		<b>No access</b> S 38 60
	<b>Keep out</b> S 38 61		<b>Do not enter</b> S 38 62		<b>No admittance</b> S 38 63
	<b>Authorized personnel only</b> S 38 64		<b>Do not enter pump room</b> Without permission from the chief officer S 38 65		<b>No entry to unauthorised personnel</b> S 38 66
	<b>No access to car deck while vessel is at sea</b> S 38 67		<b>No unauthorized persons allowed beyond this point</b> S 38 68		<b>Crew only</b> S 38 69

Prohibiting dangerous behaviour limits potential risks

Signs to Prohibit Dangerous Actions

[mm]  
300x100  
400x150



Prohibiting dangerous behaviour limits potential risks

## ⊘ PROHIBITION SIGNS (PSS)

### ISPS Code Prohibition Signs



(mm)  
300x100  
400x150



S 39 81



S 39 82



S 39 72



S 39 73



S 39 74



S 39 75



S 39 76



S 39 77



S 39 78



S 39 83



S 39 79



S 39 40



S 39 41

### Deck and Engine Room Prohibition Sign

(mm)  
300x100  
400x150



S 39 91



S 39 65



S 38 57



S 38 65



S 39 95

Galley Prohibition Signs

		 <p><b>Microwave Oven</b> 1. As a sensible precaution do not look closely in to the oven when it is switched on. 2. Metal containers such as tin foil must not be placed in this oven.</p> <p>S 40 01</p>	<p>[mm] 300x100 400x150</p>
 <p><b>Do not leave garbage here</b></p> <p>S 40 02</p>	 <p><b>Do not store raw and cooked food together</b></p> <p>S 40 03</p>	 <p><b>Do not throw garbage overboard</b> This vessel operates in a special area designated by international maritime law.</p> <p>S 40 04</p>	

Accommodation Prohibition Signs

		 <p><b>No smoking</b></p> <p>[*] S 40 11</p>	<p>[mm] 300x100 400x150 [*]600x200</p>
 <p><b>No smoking in elevator</b></p> <p>S 40 12</p>	 <p><b>This is a no smoking area</b></p> <p>S 40 13</p>	 <p><b>No smoking in bed</b></p> <p>S 40 14</p>	<p>[*] Also available in this size</p>
 <p><b>You are entering a no smoking area Please extinguish your cigarette</b></p> <p>S 40 21</p>	 <p><b>This is a no smoking cabin</b></p> <p>S 40 22</p>	 <p><b>No smoking Smoke detectors in operation</b></p> <p>S 40 23</p>	
 <p><b>Switch off mobile phones, pagers, cameras, etc</b></p> <p>S 40 15</p>	 <p><b>Do not drink</b></p> <p>S 40 17</p>	 <p><b>No workwear beyond this point</b></p> <p>S 40 16</p>	
 <p><b>Do not put foreign objects in toilet To flush close lid and press button</b></p> <p>S 40 18</p>	 <p><b>Do not put foreign objects in toilet Toilet paper and human waste only</b></p> <p>S 40 19</p>	 <p><b>Do not leave garbage here</b></p> <p>S 40 20</p>	<p>These signs are only available in white rigid plastic and white self-adhesive vinyl</p>

# HAZARD WARNING SIGNS (WSS)

## General Warning Signs







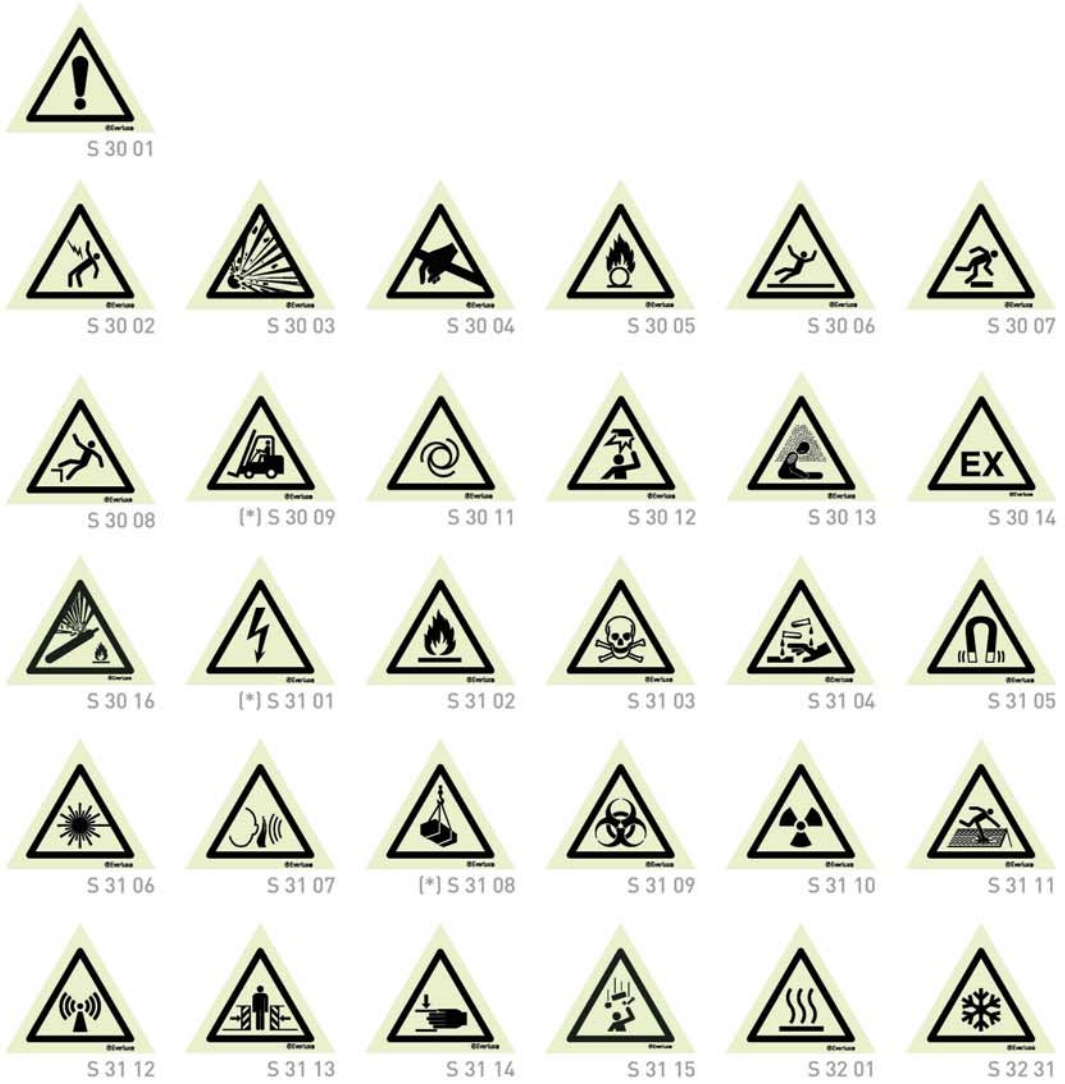

















(mm)  
 100x100  
 150x150  
 200x200  
 300x300[\*]

[\*] Also available in this size



## General Warning Signs

[mm]  
300x100  
400x150

 <b>Danger</b>	 <b>Danger</b> Unmanned machinery space machinery may start without warning	 <b>Danger</b> Battery charging	 <b>Danger</b> Low oxygen level
S 30 51	S 30 52	S 30 53	S 30 54
 <b>Danger</b> You are entering a CO <sub>2</sub> protected area	 <b>Danger</b> Moving machinery	 <b>Danger</b> Under maintenance	 <b>Danger</b> Overhead working
S 30 55	S 30 56	S 30 57	S 30 58
 <b>Danger</b> Men working below	 <b>Warning</b> Hazards	 <b>Warning</b> Hazardous area	 <b>Warning</b> Hazardous substances
S 30 60	S 30 89	S 30 61	S 30 20
 <b>Warning</b> Isolate before removing guards	 <b>Danger</b> Dust hazard	 <b>Danger</b> Asbestos	 <b>Danger</b> Solvents
S 30 62	S 30 63	S 30 64	S 30 65
 <b>Danger</b> Beware of trucks	 <b>Danger</b> Lift well	 <b>Danger</b> No escape	 <b>Warning</b> Motor starts and stops automatically
S 30 86	S 30 87	S 30 88	S 30 66
 <b>Warning</b> Pressurized cylinder	 <b>Caution</b>	 <b>Caution</b> Vehicles	 <b>Caution</b> Exhaust fumes
S 30 21	S 30 22	S 30 67	S 30 68
 <b>Caution</b> Steep stairway use handrails	 <b>Danger</b> Hot surface	 <b>Danger</b> Hot	 <b>Warning</b> Overhead hazard
S 30 69	S 30 70	S 30 71	S 30 23
 <b>Caution</b> Out of order	 <b>Warning</b> Beware of moving vehicles	 <b>Danger</b> of death	 <b>Danger</b> Petroleum vapour
S 30 59	S 30 24	S 30 72	S 30 73
 <b>Danger</b> Explosion risk	 <b>Caution</b> Explosion gases	 <b>Danger</b> Explosive material	 <b>Danger</b> Compressed gases
S 30 74	S 30 75	S 30 76	S 30 77
 <b>Danger</b> Compressed oxygen	 <b>Danger</b> Explosive atmosphere	 <b>Caution</b> Slip hazard	 <b>Caution</b> Wet deck
S 30 78	S 30 25	S 30 79	S 30 80
 <b>Caution</b> Slippery surface	 <b>Caution</b> Deck may be slippery when wet	 <b>Caution</b> Trip hazard	 <b>Caution</b> Mind the step
S 30 81	S 30 26	S 30 82	S 30 83
 <b>Danger</b> Uneven surface	 <b>Warning</b> Mind your head	 <b>Caution</b> Low overhead clearance	 <b>Warning</b> Forklift truck in operation
S 30 84	S 30 85	S 30 27	S 30 28
 <b>Warning</b> Automatic start-up	 <b>Warning</b> Overhead load	 <b>Warning</b> Stand clear of suspended load	 <b>Warning</b> Deep step
S 30 29	S 30 30	S 30 31	S 30 90
 <b>Warning</b> Floor-level obstacle	 <b>Danger</b> Risk of falling	 <b>Warning</b> Drop	 <b>Warning</b> Sudden drop
S 30 32	S 30 33	S 30 34	S 30 35



# HAZARD WARNING SIGNS (WSS)

## General Warning Signs

(mm)  
300x100  
400x150

 <b>Danger</b> High voltage	 <b>Danger</b> Electrical hazard	 <b>Danger</b> Electrical shock risk	 <b>Danger</b> Static electricity
S 31 51	S 31 52	S 31 53	S 31 54
 <b>Danger</b> 110 volts	 <b>Danger</b> 115 volts	 <b>Danger</b> 230 volts	 <b>Danger</b> 240 volts
S 31 55	S 31 56	S 30 36	S 31 57
 <b>Danger</b> 220 volts	 <b>Danger</b> 380 volts	 <b>Danger</b> 440 volts	 <b>Danger</b> 3300 volts
S 31 58	S 31 59	S 31 60	S 31 61
 <b>Danger</b> 6600 volts	 <b>Danger</b> Live terminal	 <b>Danger</b> Live wires	 <b>Danger</b> Electrocution risk
S 31 62	S 31 63	S 31 64	S 31 67
 <b>Danger</b> Flammable liquid	 <b>Danger</b> Highly flammable material	 <b>Danger</b> Fire risk	 <b>Danger</b> Highly flammable gases
S 31 65	S 31 66	S 31 67	S 31 68
 <b>Danger</b> Flammable atmosphere	 <b>Danger</b> L. P. G. Flammable	 <b>Danger</b> Low flash point	 <b>Danger</b> Toxic
S 31 69	S 31 70	S 31 71	S 31 72
 <b>Danger</b> Chlorine	 <b>Danger</b> Harmful vapours	 <b>Danger</b> Harmful chemicals	 <b>Danger</b> Cyanide
S 31 73	S 31 74	S 31 75	S 31 76
 <b>Toxic</b> Fumes	 <b>Toxic</b> Gases	 <b>Danger</b> Toxic vapours	 <b>Danger</b> Acid
S 31 88	S 31 89	S 31 90	S 31 77
 <b>Danger</b> Battery acid	 <b>Danger</b> Corrosive substance	 <b>Danger</b> Caustic	 <b>Sulphuric acid</b>
S 31 78	S 31 79	S 31 80	S 31 91
 <b>Hydrochloric acid</b>	 <b>Nitric acid</b>	 <b>Caustic</b>	 <b>High risk</b>
S 31 92	S 31 93	S 31 94	S 31 95
 <b>Hazard</b> Group 1	 <b>Hazard</b> Group 2	 <b>Hazard</b> Group 3	 <b>Warning</b> Asphyxiating atmosphere
S 31 96	S 31 97	S 31 98	S 32 02
 <b>Laser beam</b>	 <b>Caution</b>	 <b>Caution</b> Noise	 <b>Caution</b> Radiation risk
S 31 99	S 32 00	S 31 81	S 31 82
 <b>Danger</b> Ionizing radiation	 <b>Danger</b> Biological hazard	 <b>Danger of infection</b>	 <b>Caution</b> Non-ionizing radiation
S 31 83	S 31 84	S 31 85	S 31 86

Deck, Engine Room and Galley Warning Signs

 S 30 55	 S 32 12	 S 32 13	 S 30 54	[mm] 300x100 400x150
 S 32 15	 S 32 16	 S 30 71	 S 32 56	
 S 30 70	 S 32 60	 S 32 61	 S 32 62	
 S 30 37	 S 31 81	 S 32 18	 S 32 58	
 S 30 79	 S 30 20	 S 30 80	 S 30 81	
 S 30 26	 S 30 83	 S 32 59	 S 30 39	

Accommodation Warning Signs

 S 32 71	 S 32 72	 S 32 73	[mm] 300x100 400x150
 S 32 74	 S 32 75	 S 32 76	

 S 32 91	 S 32 92	 S 32 93	 S 32 94	[mm] 73x200	These signs are only available in white rigid plastic and white self-adhesive vinyl
--	---	--	--	----------------	---

# MANDATORY ACTION SIGNS (MSS)

## Fire and Watertight Door Signs

(mm)  
80x80(\*)  
100x100  
150x150  
200x200  
300x300(\*\*)



S 34 00



(\*),(\*\*) Also available in this size



S 34 01



S 34 02



S 34 03



S 34 04



S 34 05



S 34 06



S 34 07



S 34 08



S 34 09



S 34 10



S 34 11



S 34 12



S 34 13



(\*) S 34 14



(\*\*) S 34 15



(\*\*) S 34 16



(\*\*) S 34 17



S 34 18



S 34 19



(\*\*) S 34 20



S 34 21



S 34 22



S 34 23



S 34 24



S 34 25



S 34 26



S 34 27



S 34 28



(\*\*) S 34 29

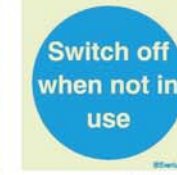

S 34 30



S 34 31



S 34 32



S 34 33



S 34 34



S 34 35



S 34 36



S 34 37



S 34 38



S 34 40



S 34 41



S 34 42



S 34 43

To prevent the obstruction of escape routes, mandatory signs should be permanently fixed on all fire and watertight doors.

Personal Protective Equipment Signs



[mm]  
100x100  
150x150  
200x200  
[\*]300x300

[\*] S 35 01

[\*] Also available in this size



[\*] S 35 02



[\*] S 35 03



[\*] S 35 04



[\*] S 35 05



[\*] S 35 06



[\*] S 35 07



S 35 08



S 35 09



S 35 10



S 35 11



S 35 12



[\*] S 35 13



S 35 14



[\*] S 35 15



[\*] S 35 16



S 35 17



[\*] S 35 18



S 35 19



S 35 20



S 35 21



S 35 22



S 35 23



S 35 24



S 35 25



S 35 26



S 35 27



S 35 28



S 35 29



S 35 31



S 35 32

# MANDATORY ACTION SIGNS (MSS)

## Personal Protective Equipment Signs

(mm)  
300x100  
400x150  
600x200(\*)

(\*) Also available in this size











 <b>Head protection must be worn</b> S 35 51	 <b>This is a safety helmet area</b> S 35 52	
 <b>Safety helmets must be worn beyond this point</b> S 35 35	 <b>Eye protection must be worn</b> (*) S 35 53	 <b>Head protection is provided for your safety and must be worn</b> S 35 36
 <b>Eye protection must be worn in this area</b> (*) S 35 54	 <b>Eye protection is provided for your safety and must be worn</b> (*) S 35 60	 <b>Wear goggles</b> (*) S 35 61
 <b>Eye protection must be worn when operating this machine</b> S 35 37	 <b>Ear protection must be worn</b> (*) S 35 55	 <b>Ear protection must be worn in this area</b> (*) S 35 62
 <b>Wear ear protection</b> (*) S 35 63	 <b>Ear protection must be worn when operating this machine</b> S 35 38	 <b>Ear protection is provided for your safety and must be worn</b> S 35 39
 <b>Respirators must be worn</b> S 35 56	 <b>Wear respirator</b> (*) S 35 64	 <b>Masks must be worn when working here</b> (*) S 35 57
 <b>Wear visor</b> S 35 40	 <b>Hand protection must be worn</b> (*) S 35 58	 <b>Wear gloves</b> S 35 65
 <b>Protective footwear must be worn</b> (*) S 35 59	 <b>Lift correctly</b> (*) S 35 66	 <b>Now wash your hands</b> S 35 71
 <b>Use adjustable guard</b> S 35 72	 <b>Wear face shield</b> S 35 73	 <b>Face protection must be worn when welding</b> S 35 86
 <b>Face protection must be worn in this area</b> S 35 87	 <b>Wear safety harness</b> S 35 74	 <b>Harness must be worn</b> S 35 41
 <b>Protective clothing is provided for your safety and must be worn</b> S 35 75	 <b>Wear protective clothing</b> (*) S 35 76	 <b>High visibility clothing must be worn beyond this point</b> S 35 77
 <b>High visibility clothing must be worn in this area</b> S 35 42	 <b>Wear laboratory coat</b> S 35 78	 <b>Wear welding mask</b> (*) S 35 79
 <b>Switch off after use</b> S 35 80	 <b>Keep locked</b> (*) S 35 81	 <b>Sound horn</b> S 35 82
 <b>To be used by trained and authorised personnel only</b> S 35 83	 <b>Oil spill equipment stored inside</b> S 35 88	 <b>Wear helmet</b> S 35 67

To ensure the correct use of protective wear, mandatory signs must be used. Mandatory actions must be marked with mandatory signs

**Personal Protective Equipment Signs**

 S 35 68	 S 35 69	 [*] S 35 70	ⓘ [mm] 300x100 400x150 [*]600x200 [*] Also available in this size
 S 35 43	 S 35 89	 S 35 90	
 S 35 91	 S 35 84	 S 35 92	
 S 35 85	 S 35 44	 S 35 45	
 S 35 46	 S 35 47	 S 35 48	

**ISPS Code Mandatory Signs**

 S 36 02	 S 36 03	 S 36 01	ⓘ [mm] 300x100 400x150
 S 36 05	 S 36 06	 S 36 04	
 S 36 08	 S 36 16	 S 36 07	
 S 36 08		 S 36 10	

**Deck and Engine Room Mandatory Signs**

 S 36 13	 S 36 11	 S 36 12	ⓘ [mm] 300x100 400x150
 S 36 13	 S 36 14	 S 36 16	
 S 36 17	 S 36 18	 S 36 19	

## MANDATORY ACTION SIGNS (MSS)

### Deck and Engine Room Mandatory Signs

(mm)  
300x100  
400x150



S 36 20



S 36 21



S 36 22

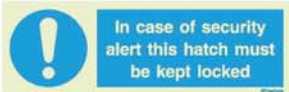

S 35 93



S 35 94

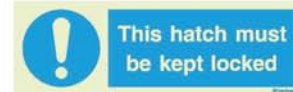

S 35 95



S 35 96



S 35 97



S 35 98

### Galley Mandatory Signs

(mm)  
300x100  
400x150  
600x200

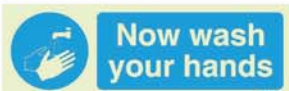

S 35 71



S 36 42



S 36 55

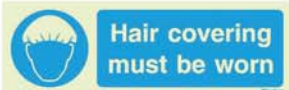

S 36 46



S 36 43



S 36 44

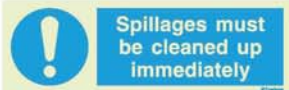

S 36 45



S 36 47



S 36 48



S 36 49



S 36 50



S 36 51



S 36 52



S 36 53



S 36 54



S 36 56



S 36 57



S 36 58



S 36 59



S 36 60



S 36 61



S 36 62



S 36 63



S 36 64

### Accommodation Signs

(mm)  
300x100  
400x150  
600x200



S 36 81



S 36 82



S 36 83

These signs are only available in white rigid plastic and white self-adhesive vinyl.

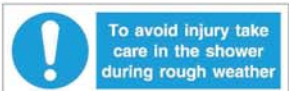

S 36 84

Multiple Signage with Combined Hazard, Mandatory and Prohibited Action Instructions

[mm]  
300x200



S 40 51



S 40 52



S 40 53



S 40 54



S 40 55



S 40 56



S 40 57



S 40 58



S 40 59



S 40 60



S 40 61



S 40 62



S 40 63



S 40 64



S 40 65



S 40 66



S 40 67



S 40 68



S 40 69



S 40 70



## MULTIPURPOSE COMBINATION SIGNS

### Multiple Signage with Combined Hazard, Mandatory and Prohibited Action Instructions

(mm)  
300x400



(mm)  
300x300



### Multiple Signage for Danger, Prohibition and Obligation

(mm)  
300x300



Multiple Signage for Danger, Prohibition and Obligation

**Battery Locker**

**Danger**  
Battery acid

No entry to unauthorised personnel  
No smoking or naked lights

Minimum safety requirements:  
Overalls  
Face shield  
Safety gloves

S 41 02

**Galley**

**No smoking**

Wash hands before preparing food

Minimum safety requirements:  
Hairnet  
Safety footwear

S 41 03

**Machinery Space**

**Caution**  
Space protected by gas flood system  
If alarm sounds vacate immediately  
Machinery may start and stop without warning

No entry to unauthorised personnel  
No smoking or naked lights except in designated areas

Minimum safety requirements:  
Overalls  
Head protection  
Ear defenders  
Safety boots

S 41 04

[mm]  
300x300

**Gas Bottle Store**

**Danger**  
Compressed gases

No entry to unauthorised personnel  
No smoking or naked lights

Keep well ventilated

S 41 05

**Paint Store**

**Danger**  
Flammable liquid

No entry to unauthorised personnel  
No smoking or naked lights

Keep well ventilated

S 41 06

**Chemical Locker**

**Danger**  
Flammable liquid

No entry to unauthorised personnel  
No smoking or naked lights

Keep well ventilated

S 41 07

**Switch Gear**

**Danger**  
High voltage

No entry to unauthorised personnel  
No smoking or naked lights

Minimum safety requirements:  
Overalls  
Safety gloves  
Ear defenders  
Safety boots

S 41 08

**Forecastle Space**

**Caution**  
Space protected by gas flood system  
If alarm sounds vacate immediately  
Machinery may start and stop without warning

No entry to unauthorised personnel  
No smoking or naked lights

Minimum safety requirements:  
Overalls  
Head protection  
Ear defenders  
Safety boots

S 41 09

**Fridge Machinery**

**Danger**  
Toxic fumes  
Machinery may start without warning

No entry to unauthorised personnel  
No smoking or naked lights

Keep well ventilated

S 41 10

**Emergency Generator**

**Danger**  
High voltage  
Machinery may start without warning

No entry to unauthorised personnel  
No smoking or naked lights

Minimum safety requirements:  
Overalls  
Safety gloves  
Ear defenders  
Safety boots

S 41 11

**Steering Gear**

**Danger**  
Moving machinery

No entry to unauthorised personnel  
No smoking or naked lights

Minimum safety requirements:  
Overalls  
Head protection  
Ear defenders  
Safety boots

S 41 12

**Pump Room**

**Caution**  
Confined space with moving machinery

No entry to unauthorised personnel  
No smoking or naked lights

Minimum safety requirements:  
Overalls  
Head protection  
Ear defenders  
Safety boots

S 41 13

**Helideck Safety Notice**

Follow Helicopter Landing Officer (HLO) instructions

No access to helideck during landing or taking off

Do not approach helicopter until anti-collision lights are turned off

Do not walk behind the helicopter

Use designated safe approach routes

**Warning**  
Beware of tail rotor

No smoking

No loose headgear

Secure all loose items

S 41 15

[mm]  
400x600

## LOW LOCATION LIGHTING

### Low Location Lighting System



The spreading of smoke is one of the most dangerous consequences of a fire rendering evacuation difficult and in some cases impossible. Under these conditions, visibility is reduced causing panic and increasing the evacuation time which is a critical factor in avoiding intoxication which can lead to death.

The © Everlux® Low Location Lighting (LLL) system is a unique system that allows all evacuation routes to stay illuminated, thereby communicating a clear, continuous and unambiguous “means of escape” message which leads to a safe place. The locations of fire fighting equipment are also clearly marked as part of the system along the escape routes.

This LLL system is unique in providing consistent and regular information throughout the complete escape route. This reduces possible confusion and panic, factors that hamper the safe egress from occupied areas. According to IMO Resolution A. 752 [18] all means of egress must be marked with Low Location Lighting system at all points of the evacuation route. The LLL system is also recommended by ISO Standards, namely ISO 15370.



The illustration below depicts a complete safety signage system installed on board:

- A** - Photoluminescent signs installed at a high location level (above 2m) are to be visible and identified from further distances.
- B** - Photoluminescent signs installed at an intermediate location level. Per ISO 24409 fire-fighting equipment signs shall be installed either directly on the fire-fighting equipment or as close as practicable. Recommended range for signs with text providing information and/or instructions to the user.
- C** - Photoluminescent signs at a low location level (within 30cm from deck according to SOLAS 2004 Chapter II Regulation 13.3.3.5 and ISO 15370): a sign system that illuminates the entire escape route and identifies the location of fire fighting equipment at floor level.

Examples

Escape doors should be signed as illustrated.

Stairwells and corridors which are 2m wide or wider should be fitted with LLL photoluminescent strips on both sides.

Photoluminescent directional signs must be placed at each change of level.

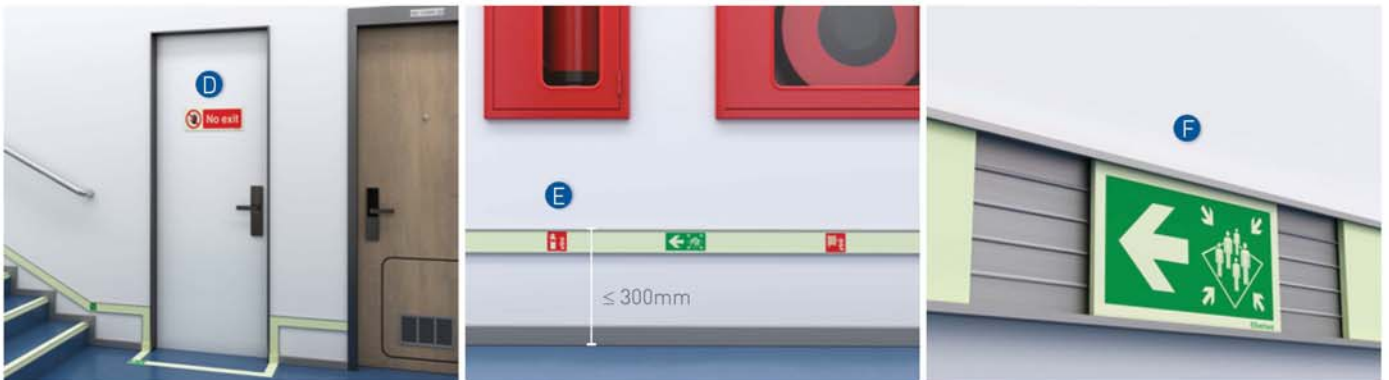

No exit signs must be posted on doors that are not part of the escape route.

According to Solas 2004 Chapter II Regulation 13.3.3.5 and IMO Resolution A.752 [18] photoluminescent marking strips must be placed not more than 30cm above the deck at all points of the escape route.

Directional photoluminescent signs complement the continuous photoluminescent strip installed in aluminium rail.

## LOW LOCATION LIGHTING

### Normative and Legal Framework, Technical Performances and Properties

Guidance systems at floor level (Low Location Lighting) began with legislation covering the areas of greatest risk. Firstly in aviation with FAA in 1984 and then in the maritime industry with IMO Regulations in 1989. Since 1999, following the development of new photoluminescent technologies, other authorities have begun the process of standardising these systems.

IMPORTANT STANDARDS	IMO Resolution A.752 [18]	Guidelines for the evaluation, testing and application of low-location lighting on passenger ships
	SOLAS Convention 2004	Means of escape - Marking of escape routes
	European Directive 2014/90/EU	Safety rules and standards for passenger ships
	ISO 15370	Low Location Lighting (LLL) on passenger ships
	ISO 16069	SWGS - Safety Way Guidance Systems
	ISO 3864	Graphical symbols - safety colours and safety signs

#### ⊗ Everlux® Low Location Lighting Strip and Sign System:

The strip and sign system can be mounted directly to walls using the ⊗ Everlux® adhesive or with the aluminium frames.

According to IMO A.752 [18] this system shall be positioned in the following way, throughout the escape routes:

- Where a corridor has a width of 2m or more the guidance line shall be applied continuously on both sides of the corridor.
- Where the width is less than 2m, one guidance line may be sufficient and should be as continuous as possible on the side where the fire fighting equipment is located. If there is no fire fighting equipment the strips should be applied continuously on the side that leads to the door handle.
- The strips should not be installed more than 300mm above deck.

Strip and Sign System for Floors and Stairs:

The strip and sign system can be placed directly onto floors and stairs using the integral high adherence adhesive. Simply remove the backing material and position accurately.

Luminance Properties			
Applicable Resolutions and Standards/ Product	Luminance Intensity (mcd/m <sup>2</sup> ) (After removing the exciting light)		Period of Light Decay Luminance Intensity greater than a 0.3 mcd/ m <sup>2</sup>
	10 minutes	60 minutes	
IMO Resolution A.752[18] a)	15 mcd/m <sup>2</sup>	2.0 mcd/m <sup>2</sup>	...
ISO 15370 a)	15 mcd/m <sup>2</sup>	2.0 mcd/m <sup>2</sup>	...
⊗ Everlux® a)	<b>57 mcd/m<sup>2</sup></b>	<b>10.7 mcd/m<sup>2</sup></b>	<b>3000 minutes</b>
⊗ Everlux®-LLL b)	<b>80 mcd/m<sup>2</sup></b>	<b>10 mcd/m<sup>2</sup></b>	<b>1000 minutes</b>

a) Values obtained with a stimulation of only 25 lux, during 24 hours with a fluorescent lamp with colour temperature of 4000K, according to ISO 15370 measurement protocol.

b) Values obtained with a stimulation of only 25 lux, during 15 minutes with a fluorescent lamp with colour temperature of 6500K, according to ISO 16069 measurement protocol.

All signs have a high photoluminescent intensity which is achieved with as little as a 25 lux charge from an ambient light source

#### Base Materials:

**Signs and strips for wall mounting:** Photoluminescent rigid plastic 1.2mm thick; photoluminescent self-adhesive vinyl;

**Signs and strips for floors and stairs:** Photoluminescent non-slip self-adhesive polycarbonate 0.62mm thick;

Transparent vinyl signs are also available to complement the ⊗ Everlux® Low Location Lighting system.

**Printing:** Serigraphy, high gloss paint with a high UV resistance.

**Chemical Characteristics:** Non-phosphorous, non-radioactive, lead-free and non-poisonous.

## Turnkey Safety Signage Projects



Ⓢ Everlux® adopts an integrative approach to every safety signage project the company is involved with, from project development through installation and commissioning. When hiring Ⓢ Everlux® for a turnkey safety signage project, customers benefit from a high quality on time service which includes on-board and remote surveys, life-safety and fire control plan and Low Location Lighting project development using the Ⓢ Everlux® Project maritime tool, supply, installation, on-board luminance measurements, project management, documentation and delivery.

The Ⓢ Everlux® turnkey safety signage project service is the ideal solution for owners, shipyards or marine outfitters who are involved with new-build or major refurbishment on vessels or oil rigs.

## Photoluminescent Low Location Lighting System Inspections and Measurement Service

Ⓢ Everlux® has the Approval as Service Supplier by DNV for Low Location Lighting luminance measurements.

Our technicians are available worldwide to help you meet the classification bodies' requirements in a fast and cost-effective way.

The inspection and measurement reports on LLL systems are mandatory according to IMO Resolution A.752 [18], adopted on 4 November 1993. These guidelines cover the approval, installation and maintenance of low location lighting (LLL) required by regulations II-2/28, paragraph 1.10 and II-2/41-2, paragraph 4.7 of the 1974 SOLAS Convention, as amended, on all passenger ships carrying more than 36 passengers, to readily identify the passengers' route of escape when the normal emergency lighting is less effective due to smoke.

According to IMO Resolution A.752 [18], chapter 9, a maintenance of LLL systems should be visually examined and checked once a week and a record kept. All missing, damaged or inoperable LLL components should be replaced.

All LLL systems should have their luminance tested at least once every five years.

Readings should be taken on site. If the luminance for a particular reading does not meet the requirements, additional readings shall be taken. The readings shall be taken adjacent to the location of the non-compliant readings. The installation is acceptable when the spacing of the non-compliant readings does not exceed 2 m. Otherwise, the LLL component shall be replaced or the illumination increased to meet the requirements.



For detailed information on the Ⓢ Everlux® turnkey safety signage project service or on the mandatory requirements, inspection and measurement reports of photoluminescent LLL systems, please contact us at [commercial@everluxmaritime.com](mailto:commercial@everluxmaritime.com).



© Everlux® project maritime is a software support tool for the development of safety signage and Low Location Lighting (LLL) projects and respective bill of quantities. This tool facilitates the most adequate selection of safety signs and provides installation companies with the right technical documentation to assure that the safety signs that are projected will be installed onboard simultaneously reducing the installation time.

© Everlux® project maritime is available in two different versions: version 3.0 and version 3.0i. In terms of hardware both versions can be used with 64 bit processors. The 3.0 version works on AutoCAD (post 2012 versions except AutoCAD LT) and after its installation will automatically generate a tool bar with the © Everlux® project maritime menu.

The 3.0i version is an independent application that allows the use of image files (type \*.dxf; \*.jpg; \*.bmp; \*.png) as the basis for the safety signage project.

© Everlux® project maritime is available for free download at: [www.everluxmaritime.com/en/downloads](http://www.everluxmaritime.com/en/downloads)

## AutoCAD Symbols for Fire & Safety Control Plans

**Everlux®**

**AUTOCAD SYMBOLS  
FOR FIRE & SAFETY  
CONTROL PLANS**

IMO Resolution A.1116 [30] - Escape Route Signs and Equipment Location Markings is now in force. This recent resolution introduced graphical changes to shipboard safety signs to allow for an easier understanding of the signs by crews and passengers. These new signs have been available in the Everlux catalogue and the Everlux website ever since ISO 24409 was published.

In addition to its safety signs, Everlux is now providing a file with AutoCAD blocks with the graphical symbols compliant with IMO Resolution A.1116 [30]. This is particularly useful for shipyards and naval architects involved in the development of Fire & Safety Control Plans.

The AutoCAD file with the IMO Resolution A.1116 [30] is available free of charge. If you are interested in receiving it, please e-mail us at [commercial@everluxmaritime.com](mailto:commercial@everluxmaritime.com) or contact us via our website [www.everluxmaritime.com](http://www.everluxmaritime.com).

Signs for Wall Marking at Floor Level

The signs featured in this page can be supplied in photoluminescent rigid plastic, self-adhesive photoluminescent vinyl and transparent self-adhesive vinyl. The transparent self-adhesive vinyl signs are a quick solution to complement Low Location Lighting systems by applying them directly on to the photoluminescent strips.

[mm]  
107x57  
158x83



S 20 01

S 20 02

S 20 03

S 20 04

S 20 05

S 20 06

S 20 07

S 20 08

S 20 09

S 20 10



S 20 21

S 20 22

S 20 23

S 20 24

S 20 25

S 20 26

S 20 27

S 20 28

S 20 29

S 20 81

S 20 82

S 20 83

S 20 84

[mm]  
57x57  
83x83



(\*) S 20 31

(\*) S 20 32

S 20 47

S 20 49

S 20 40

S 20 51

S 20 50

S 20 54

S 20 55

(\*) S 20 33

(\*) S 20 34

S 20 42

S 20 43

S 20 46

S 20 44

S 20 41

S 20 52

[mm]  
57x57  
83x83  
(\*)75x57  
(\*)110x83



S 20 61

[mm]  
107x57  
158x83



S 20 65



S 20 66



S 20 67

[mm]  
107x57  
158x83

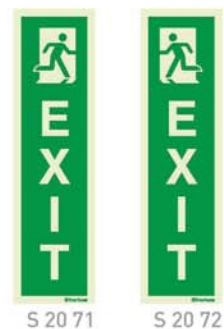

S 20 71

S 20 72

[mm]  
57x200  
83x300

Available in photoluminescent rigid plastic and non-slip self-adhesive polycarbonate.



S 20 75

[mm]  
200x40



## LOW LOCATION LIGHTING

### Strips for Wall Marking at Floor Level

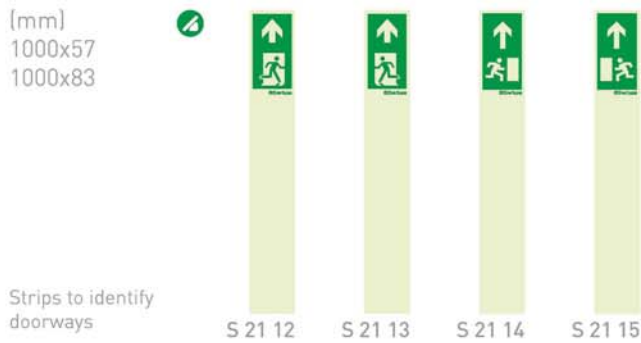

### Rolls for Wall Marking

length [m]  
10

The **Everlux**® photoluminescent vinyl rolls can be used in wall mounted LLL systems and are the ideal solution for applications in irregular or rounded walls. This product can also be used for emergency equipment marking and handrail identification.

width [mm]  
35  
57  
83



System for Floor and Stair Marking

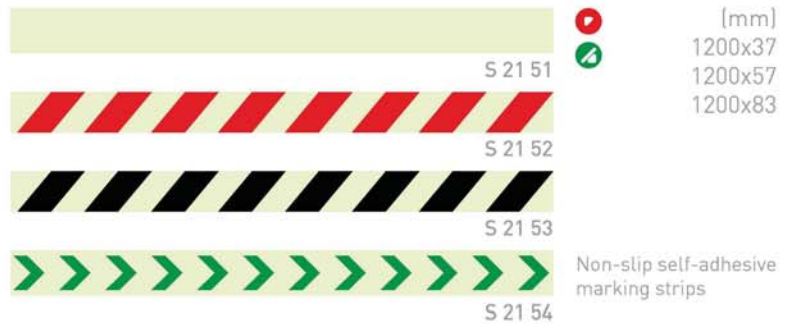

⊗ Everlux®-LLL Discs

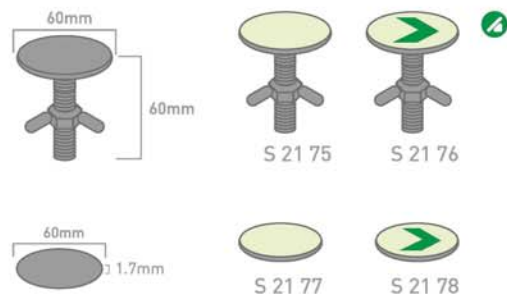
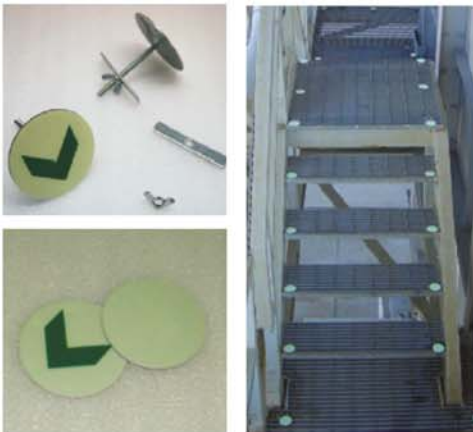

Discs for mesh metal floors  
Ø60 – 1 box of 12 units

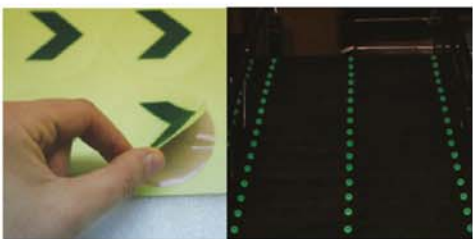

Non-slip self-adhesive discs for floors  
Ø40 – 1 sheet of 16 units  
Ø60 – 1 sheet of 18 units  
Ø100 – supplied by the unit

⊗ Everlux®-LLL Footprint Silhouettes

Photoluminescent footprint silhouettes are ideal for indicating the direction and outline of evacuation routes. Available in left and right silhouettes to be used alternately, ⊗ Everlux®-LLL Footprint Silhouettes are made from self-adhesive, anti-slip polycarbonate which is only 0.03mm thick.

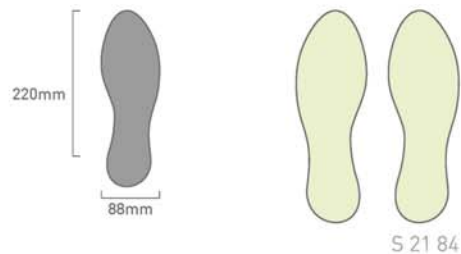
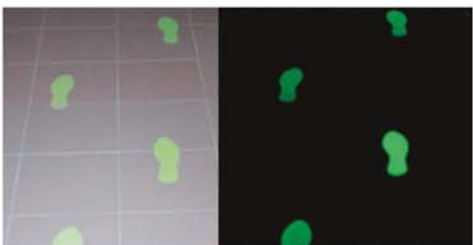

## LOW LOCATION LIGHTING

### Non-Slip Self-Adhesive "L" for Stairs

Designed to mark the edges of the steps. Supplied in sheets of 4 units (two signs per step)

In every flight of steps, the limits of the first and the final steps should be fully signed. You should use the strips code S 21 51

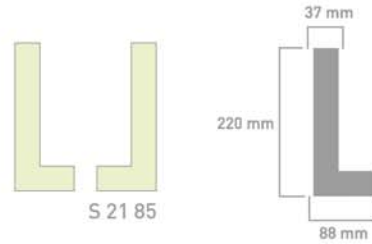

### Stairnosing - Protection for Steps

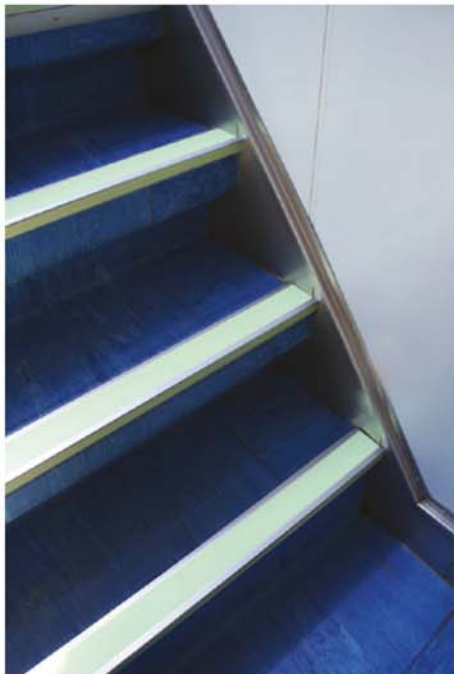

Protection for steps

S 21 90

Aluminium framework developed for stair nosing protection. This product has anti-slip properties, even in situations where oil has been spilt, due to the grooves featured over the whole surface.

On the upper and front parts there are **Everlux<sup>®</sup>-LLL** photoluminescent polycarbonate strips which also have anti-slip properties. These allow the perfect identification of the edge of the steps during a descending or ascending evacuation.

#### Properties

Materials: Aluminium and **Everlux<sup>®</sup>-LLL** in 0.62mm thick polycarbonate.

Sizes: Please refer to the technical drawings.

The **Everlux<sup>®</sup>** protection for steps is supplied with double-sided high adherence adhesive which allows an easy application.

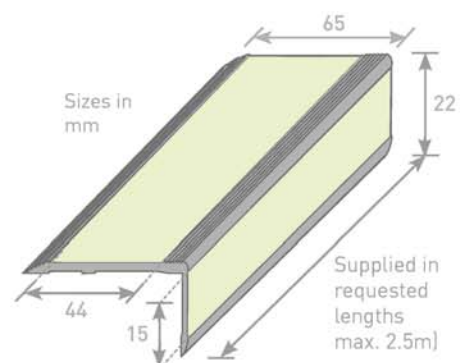

Join the frame at two points, as in scheme 1, then rotate towards the riser until it is firmly adhered (scheme 2).

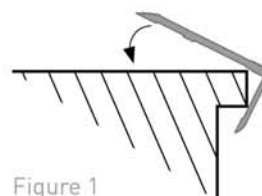

Figure 1

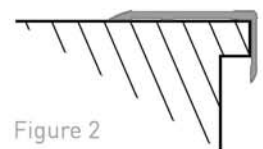

Figure 2